

**In-line Terminal Box with Optional Protection**

**TELECOM OUTSIDE PLANT**

**Use**

This is used in terminating cables of secondary telephone networks to the cable pairs of subscriber lines.

The VX-connection module provides a connection point between an exchange-side cable pair and a distribution pair. It incorporates a 5-point plug-in module to provide continuity and a range of other options. Removal of the plug-in module does not disturb wire connections but makes contacts to them available for testing to both sides of the network.

It is especially recommended for:

- \* outdoor connections where the environmental conditions are extremely aggressive,
- \* terminations where user development characteristics require future flexibility in terms of the type of protection or filtering capabilities.

**Description**

The box consists of a body and cover which house VX modules on a DIN rail. Provision for wall mounting is incorporated in the body of the box.

The lid has various opening positions, which can be selected according to the amount of working space available, and is also fitted with a seal to limit water entry.

Grommets are provided for dropwire and pair access.

The box locking mechanism is mounted in the base and is effective on closing the box; to open the box again a special key or a screwdriver is required depending upon the lock type.

The connection modules are designed for mounting on a standard DIN rail and can therefore be mounted in a variety of housings in whatever quantities are required. The small footprint (2 cm wide) ensures a compact product.

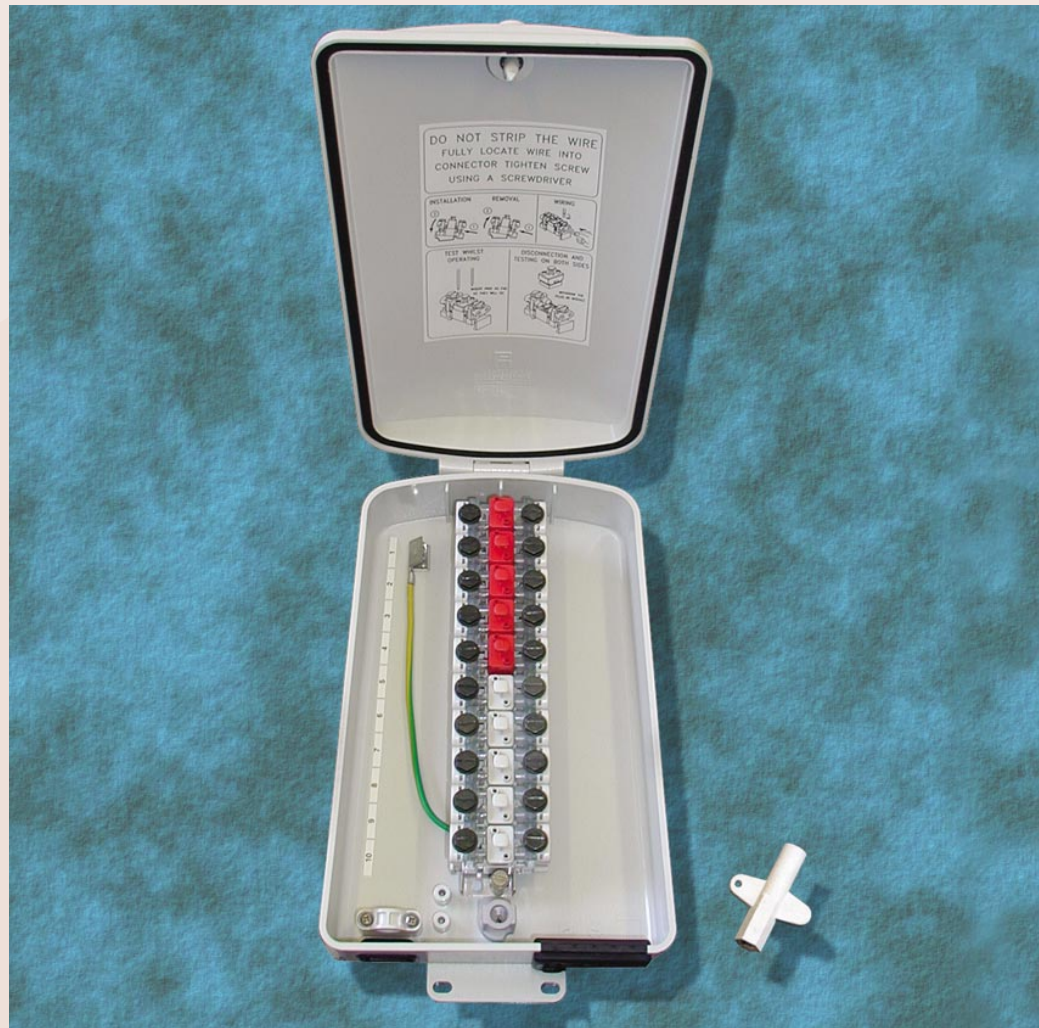

V X - T B L

# VX-TBL

## Dimensions

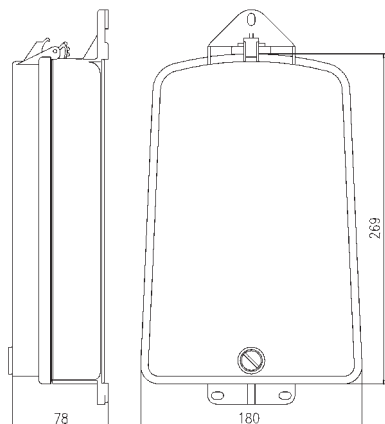

## Ordering information

Description	Number of pairs	Plug-in module configuration	Plug-in module test access type	Order number
VX-TBL-10-P	10	Continuity	Pins	7 12246-000
VX-TBL-10-C	10	230 V GDT	Crocodile	148914-000

For other configurations, please consult your local Tyco Electronics sales engineer.

## Specifications

### Contact characteristics

#### Drop wire connector

Gauge range	0.4 to 1.2 mm $\phi$
Insulation diameter	5 mm max. $\phi$

#### Pair connector

Gauge range	0.4 to 1.2 mm $\phi$
Insulation diameter	3 mm max. $\phi$

#### Current conducting capacity

20 A, 10 A per conductor for 10 minutes at least without causing deformation of the module  
(If > 20 A up to 30 A is required, this is possible using a different GDT)

#### Insulation resistance

Dry atmosphere	> $10^{12} \Omega$
Damp atmosphere (ASTM D618)	> $10^{12} \Omega$
Salt fog (ASTM B117)	> $10^{10} \Omega$
Immersion in water (15 days in 3 % NaCl solution)	> $10^{10} \Omega$

#### Contact resistance

$R_{\text{material}} + R_{\text{bridge contacts}} + R_{\text{wire contacts}}$	< 10 m $\Omega$
---	-----------------

#### Increase in contact resistance

- After climatic tests	< 2.5 m $\Omega$
- After 50 reinsertions	< 2.5 m $\Omega$

<b>Dielectric strength</b>	> 3,000 Vdc for 1 minute
----------------------------	--------------------------

### Mechanical characteristics

Base	Polycarbonate RAL 7035
Cover	Polycarbonate RAL 7035
Cover seal	Black neoprene
Pair/drop wire housing screw	Special passivated direct + lacquered Zamac alloy
Drop wire housing body	Transparent polycarbonate
Body	VO glass-fiber reinforced polycarbonate
Insertion contacts	Tinned phosphor bronze
Ground contacts	Cu-Zn-Ni-Ag alloy
Continuity contacts	Tinned hard brass
Lower sealant	Epoxy resin
Upper cable sealant	Silicone fluid
Pair/drop wire bearing cover	Polycarbonate
Plug-in module body	VO glass-fiber reinforced polycarbonate
Plug-in module sealant	Gel
"O"-ring	EPDM
Spring	Stainless steel
Cable/drop wire membrane	Thermoplastic rubber

Tyco and VX are trademarks of Tyco International

The information given herein, including drawings, illustrations and schematics which are intended for illustration purposes only, is believed to be reliable. However, Tyco Electronics makes no warranties as to its accuracy or completeness and disclaims any liability in connection with its use. Tyco Electronics' obligations shall only be as set forth in Tyco Electronics' Standard Terms and Conditions of Sale for this product and in no case will Tyco Electronics be liable for any incidental, indirect or consequential damages arising out of the sale, resale, use or misuse of the product. Users of Tyco Electronics products should make their own evaluation to determine the suitability of each such product for the specific application.

## Mondragon Telecommunications S.L.

Polígono industrial Mediterráneo  
C/. La Fila, parcela 1  
46550 Albuixech-Valencia, España  
Tel.: 34-96-141 70 72  
Fax: 34-96-141 74 15

## Tyco Electronics Raychem NV

**Telecom Outside Plant**  
Diestsesteenweg 692  
3010 Kessel-Lo, Belgium  
Tel.: 32-16 351 011  
Fax: 32-16 351 697  
www.tycoelectronics.com

## Tyco Electronics Corporation

**Telecom Outside Plant**  
8000 Purfoy, Rd.  
Fuquay-Varina, NC 27526, USA  
Tel.: 1-919-557 8600  
Fax: 1-919-557 8404